

Major rework task: 1: Redrawn of all original circuit. 2) dismantel of the entire circuitry. 3) replacement of impedece filter (blown). ) 4) Replacement of electromagnetic speaker because burned out. 5) Replacement of valves 6D6–broken– 80, because open filament. (6V6 because exausted. 6) 100% reconstruction with modern components, 7) Minor circuit modification due to replacement of double diode 80 (out of market) with solid state diodes..8) general refurbishing of furniture, dials, chassi.

A.E.Rinaldo

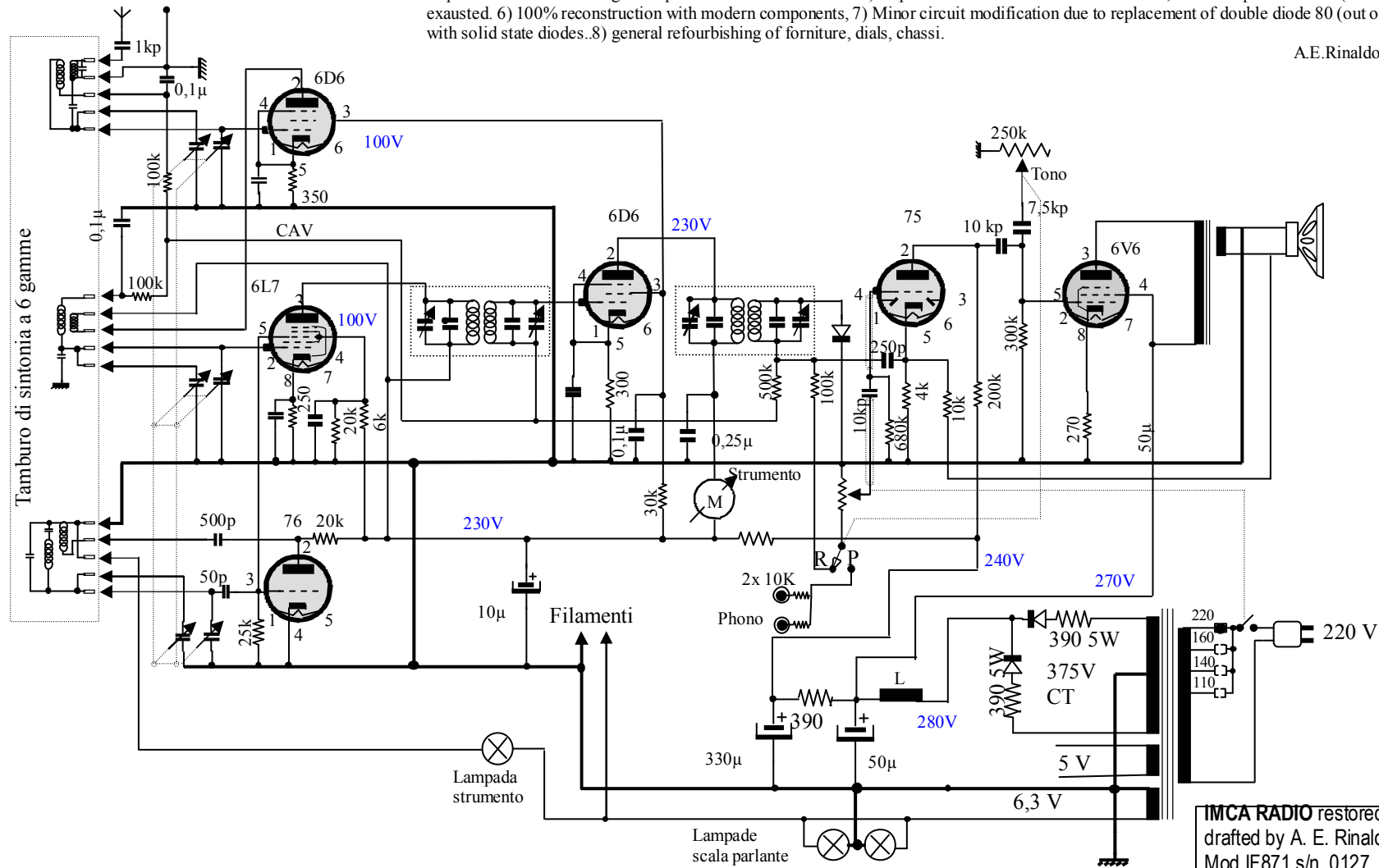

IMCA RADIO restored and drafted by A. E. Rinaldo. Mod IF871 s/n. 0127

Tambre, november 2007